

OPC 10000-1

OPC Unified Architecture

Part 1: Overview and Concepts

Release 1.04

2017-11-22

| | | | |
|---------------------|---------------------------------------------------------------|-----------|-----------------------------------------------------------------------------------------------------------------|
| Specification Type: | Industry Standard Specification | Comments: | Report or view errata: http://www.opcfoundation.org/errata |
| Document Number | OPC 10000-1 | | |
| Title: | OPC Unified Architecture Part 1 :Overview and Concepts | Date: | 2017-11-22 |
| Version: | Release 1.04 | Software: | MS-Word |
| | | Source: | OPC 10000-1 - UA Specification Part 1 - Overview and Concepts 1.04.docx |
| Author: | OPC Foundation | Status: | Release |

CONTENTS

| | Page |
|-----------------------------------------------|------|
| FOREWORD | iv |
| <u>AGREEMENT OF USE</u> | iv |
| Revision 1.04 Highlights | vi |
| 1 Scope | 1 |
| 2 Reference documents | 1 |
| 3 Terms, definitions, and abbreviations | 2 |
| 3.1 Document conventions | 2 |
| 3.2 Terms and definitions | 2 |
| 3.4.7 Abbreviations | 6 |
| 4 Structure of the OPC UA series | 7 |
| 4.1 Specification organization | 7 |
| 4.2 Core specification parts | 7 |
| 4.3 Access Type specification parts | 8 |
| 4.4 Utility specification parts | 8 |
| 5 Overview | 8 |
| 5.1 UA scope | 8 |
| 5.2 General | 9 |
| 5.3 Design goals | 9 |
| 5.4 Integrated models and services | 11 |
| 5.4.1 Security model | 11 |
| 5.4.2 Integrated AddressSpace model | 12 |
| 5.4.3 Integrated object model | 12 |
| 5.4.4 Integrated services | 12 |
| 5.5 Sessions | 12 |
| 6 Systems concepts | 13 |
| 6.1 Client Server Overview | 13 |
| 6.2 OPC UA Clients | 13 |
| 6.3 OPC UA Servers | 14 |
| 6.3.1 General | 14 |
| 6.3.2 Real objects | 14 |
| 6.3.3 Server application | 14 |
| 6.3.4 OPC UA AddressSpace | 14 |
| 6.3.5 Subscription entities | 15 |
| 6.3.6 OPC UA Service Interface | 15 |
| 6.3.7 Server to Server interactions | 15 |
| 6.4 Redundancy | 16 |
| 6.5 Publish-Subscribe | 17 |
| 6.6 Synergy of models | 17 |
| 7 Service Sets | 18 |
| 7.1 General | 18 |
| 7.2 Discovery Service Set | 18 |
| 7.3 SecureChannel Service Set | 18 |
| 7.4 Session Service Set | 19 |
| 7.5 NodeManagement Service Set | 19 |

7.6 View Service Set..... 19
7.7 Query Service Set..... 20
7.8 Attribute Service Set 20
7.9 Method Service Set..... 20
7.10 MonitoredItem Service Set 20
7.11 Subscription Service Set 21

FIGURES

Figure 1 – OPC UA Specification Organization 7
Figure 2 – OPC UA Target applications 10
Figure 3 – OPC UA System architecture 13
Figure 4 – OPC UA Client architecture 13
Figure 5 – OPC UA Server architecture 14
Figure 6 – Peer-to-peer interactions between Servers 16
Figure 7 – Chained Server example..... 16
Figure 8 – Integrated Client Server and PubSub models 18
Figure 9 – SecureChannel and Session Services 19

TABLES

No table of figures entries found.

OPC FOUNDATION

UNIFIED ARCHITECTURE –

FOREWORD

This specification is the specification for developers of OPC UA applications. The specification is a result of an analysis and design process to develop a standard interface to facilitate the development of applications by multiple vendors that shall inter-operate seamlessly together.

Copyright © 2006-2018, OPC Foundation, Inc.

AGREEMENT OF USE

COPYRIGHT RESTRICTIONS

Any unauthorized use of this specification may violate copyright laws, trademark laws, and communications regulations and statutes. This document contains information which is protected by copyright. All Rights Reserved. No part of this work covered by copyright herein may be reproduced or used in any form or by any means--graphic, electronic, or mechanical, including photocopying, recording, taping, or information storage and retrieval systems--without permission of the copyright owner.

OPC Foundation members and non-members are prohibited from copying and redistributing this specification. All copies must be obtained on an individual basis, directly from the OPC Foundation Web site <http://www.opcfoundation.org>.

PATENTS

The attention of adopters is directed to the possibility that compliance with or adoption of OPC specifications may require use of an invention covered by patent rights. OPC shall not be responsible for identifying patents for which a license may be required by any OPC specification, or for conducting legal inquiries into the legal validity or scope of those patents that are brought to its attention. OPC specifications are prospective and advisory only. Prospective users are responsible for protecting themselves against liability for infringement of patents.

WARRANTY AND LIABILITY DISCLAIMERS

WHILE THIS PUBLICATION IS BELIEVED TO BE ACCURATE, IT IS PROVIDED "AS IS" AND MAY CONTAIN ERRORS OR MISPRINTS. THE OPC FOUNDATION MAKES NO WARRANTY OF ANY KIND, EXPRESSED OR IMPLIED, WITH REGARD TO THIS PUBLICATION, INCLUDING BUT NOT LIMITED TO ANY WARRANTY OF TITLE OR OWNERSHIP, IMPLIED WARRANTY OF MERCHANTABILITY OR WARRANTY OF FITNESS FOR A PARTICULAR PURPOSE OR USE. IN NO EVENT SHALL THE OPC FOUNDATION BE LIABLE FOR ERRORS CONTAINED HEREIN OR FOR DIRECT, INDIRECT, INCIDENTAL, SPECIAL, CONSEQUENTIAL, RELIANCE OR COVER DAMAGES, INCLUDING LOSS OF PROFITS, REVENUE, DATA OR USE, INCURRED BY ANY USER OR ANY THIRD PARTY IN CONNECTION WITH THE FURNISHING, PERFORMANCE, OR USE OF THIS MATERIAL, EVEN IF ADVISED OF THE POSSIBILITY OF SUCH DAMAGES.

The entire risk as to the quality and performance of software developed using this specification is borne by you.

RESTRICTED RIGHTS LEGEND

This Specification is provided with Restricted Rights. Use, duplication or disclosure by the U.S. government is subject to restrictions as set forth in (a) this Agreement pursuant to DFARs 227.7202-3(a); (b) subparagraph (c)(1)(i) of the Rights in Technical Data and Computer Software clause at DFARs 252.227-7013; or (c) the Commercial Computer Software Restricted Rights clause at FAR 52.227-19 subdivision (c)(1) and (2), as applicable. Contractor / manufacturer are the OPC Foundation, 16101 N. 82nd Street, Suite 3B, Scottsdale, AZ, 85260-1830

COMPLIANCE

The OPC Foundation shall at all times be the sole entity that may authorize developers, suppliers and sellers of hardware and software to use certification marks, trademarks or other special designations to indicate compliance with these materials. Products developed using this specification may claim compliance or conformance with this specification if and only if the software satisfactorily meets the certification requirements set by the OPC Foundation. Products that do not meet these requirements may claim only that the product was based on this specification and must not claim compliance or conformance with this specification.

TRADEMARKS

Most computer and software brand names have trademarks or registered trademarks. The individual trademarks have not been listed here.

GENERAL PROVISIONS

Should any provision of this Agreement be held to be void, invalid, unenforceable or illegal by a court, the validity and enforceability of the other provisions shall not be affected thereby.

This Agreement shall be governed by and construed under the laws of the State of Minnesota, excluding its choice or law rules.

This Agreement embodies the entire understanding between the parties with respect to, and supersedes any prior understanding or agreement (oral or written) relating to, this specification.

ISSUE REPORTING

The OPC Foundation strives to maintain the highest quality standards for its published specifications, hence they undergo constant review and refinement. Readers are encouraged to report any issues and view any existing errata here: <http://www.opcfoundation.org/errata>.

Revision 1.04 Highlights

The following table includes the Mantis issues resolved with this revision.

| Mantis ID | Summary | Resolution |
|------------------|----------------------------------------|-------------------------------------------------------------------------------------|
| 3500 | Add PubSub Description and Term. | Added clauses 6.5 and 6.6 and other text throughout to include PubSub introduction. |
| 3787 | Definition of Certificate is incorrect | Improved the definition of Certificate |

OPC Unified Architecture Specification

Part 1: Overview and Concepts

1 Scope

Part 1 presents the concepts and overview of the OPC Unified Architecture (OPC UA). Reading this document is helpful to understand the remaining parts of this multi-part document set. Each of the other parts is briefly explained along with a suggested reading order. This Part is non-normative.

2 Reference documents

The following documents, in whole or in part, are normatively referenced in this document and are indispensable for its application. For dated references, only the edition cited applies. For undated references, the latest edition of the referenced document (including any amendments and errata) applies.

OPC 10000-2, *OPC Unified Architecture - Part 2: Security Model*

<http://www.opcfoundation.org/UA/Part2/>

OPC 10000-3, *OPC Unified Architecture - Part 3: Address Space Model*

<http://www.opcfoundation.org/UA/Part3/>

OPC 10000-4, *OPC Unified Architecture - Part 4: Services*

<http://www.opcfoundation.org/UA/Part4/>

OPC 10000-5, *OPC Unified Architecture - Part 5: Information Model*

<http://www.opcfoundation.org/UA/Part5/>

OPC 10000-6, *OPC Unified Architecture - Part 6: Mappings*

<http://www.opcfoundation.org/UA/Part6/>

OPC 10000-7, *OPC Unified Architecture - Part 7: Profiles*

<http://www.opcfoundation.org/UA/Part7/>

OPC 10000-8, *OPC Unified Architecture - Part 8: Data Access*

<http://www.opcfoundation.org/UA/Part8/>

OPC 10000-9, *OPC Unified Architecture - Part 9: Alarms and Conditions*

<http://www.opcfoundation.org/UA/Part9/>

OPC 10000-10, *OPC Unified Architecture - Part 10: Programs*

<http://www.opcfoundation.org/UA/Part10/>

OPC 10000-11, *OPC Unified Architecture - Part 11: Historical Access*

<http://www.opcfoundation.org/UA/Part11/>

OPC 10000-12, *OPC Unified Architecture - Part 12: Discovery and Global Services*

<http://www.opcfoundation.org/UA/Part12/>

OPC 10000-13, *OPC Unified Architecture - Part 13: Aggregates*

<http://www.opcfoundation.org/UA/Part13/>

OPC 10000-14, *OPC Unified Architecture - Part 14: PubSub*

<http://www.opcfoundation.org/UA/Part14/>

3 Terms, definitions, and abbreviations

3.1 Document conventions

Throughout this document and the referenced other Parts of the series, certain document conventions are used.

Italics are used to denote a defined term or definition that appears in the “Terms and definition” clause in one of the Parts of the series.

Italics are also used to denote the name of a service input or output parameter or the name of a structure or element of a structure that are usually defined in tables.

The italicized terms and names are also often written in camel-case (the practice of writing compound words or phrases in which the elements are joined without spaces, with each element's initial letter capitalized within the compound). For example the defined term is *AddressSpace* instead of Address Space. This makes it easier to understand that there is a single definition for *AddressSpace*, not separate definitions for Address and Space.

3.2 Terms and definitions

For the purposes of this document, the following terms apply.

3.3

AddressSpace

collection of information that a *Server* makes visible to its *Clients*

Note 1 to entry: See OPC 10000-3 for a description of the contents and structure of the *Server AddressSpace*.

3.4

Aggregate

a function that calculates derived values from *Raw data*

Note 1 to entry: Raw data may be from a historian or buffered real time data. Common Aggregates include averages over a given time range, minimum over a time range and maximum over a time range.

3.5

Alarm

type of *Event* associated with a state condition that typically requires acknowledgement

Note 1 to entry: See OPC 10000-9 for a description of *Alarms*.

3.6

Attribute

primitive characteristic of a *Node*

Note 1 to entry: All *Attributes* are defined by OPC UA, and may not be defined by *Clients* or *Servers*. *Attributes* are the only elements in the *AddressSpace* permitted to have data values.

3.7

Broker

intermediary program module that routes *NetworkMessages* from *Publishers* to *Subscribers*

Note 1 to entry: Brokers are building blocks of *Message Oriented Middleware*.

3.8

Certificate

digitally signed data structure that contains a public key and the identity of a *Client* or *Server*

3.9

Client

software application that sends *Messages* to OPC UA *Servers* conforming to the *Services* specified in this set of specifications

3.10

Condition

generic term that is an extension to an *Event*

Note 1 to entry: A *Condition* represents the conditions of a system or one of its components and always exists in some state.

3.11

Communication Stack

layered set of software modules between the application and the hardware that provides various functions to encode, encrypt and format a *Message* for sending, and to decode, decrypt and unpack a *Message* that was received

3.12

Complex Data

data that is composed of elements of more than one primitive data type, such as a structure

3.13

DataSet

list of named data values

Note 1 to entry: A *DataSet* typically consists of *Event* fields or *Variable* values..

3.14

DataSetMessage

payload of a *NetworkMessage* created from a *DataSet*

Note 1 to entry: The *DataSetMessage* is an immutable payload of the *NetworkMessage* handed off to the *Message Oriented Middleware* (transport layer) for delivery by the *Publisher*. The *Subscriber* receives the *DataSetMessage* as the payload of a *NetworkMessage* from the *Publisher* with additional headers that may be supplied by the *Message Oriented Middleware* along the way.

3.15

Discovery

process by which *Client* obtains information about *Servers*, including endpoint and security information

3.16

Event

generic term used to describe an occurrence of some significance within a system or system component

3.17

EventNotifier

special *Attribute* of a *Node* that signifies that a *Client* may subscribe to that particular *Node* to receive *Notifications* of *Event* occurrences

3.18

Information Model

organizational framework that defines, characterizes and relates information resources of a given system or set of systems.

Note 1 to entry: The core address space model supports the representation of *Information Models* in the *AddressSpace*. See OPC 10000-5 for a description of the base OPC UA *Information Model*.

3.19

Message

data unit conveyed between *Client* and *Server* that represents a specific *Service* request or response

3.20

Message Oriented Middleware

infrastructure supporting sending and receiving *NetworkMessages* between distributed systems

Note 1 to entry: An OPC UA *Application* may support different types of *Message Oriented Middleware* infrastructures and protocols like AMQP or UADP with IP multicast. Other types like DDS, MQTT or XMPP can also be integrated into the OPC UA *PubSub* model.

3.21

Method

callable software function that is a component of an *Object*

3.22

MonitoredItem

Client-defined entity in the *Server* used to monitor *Attributes* or *EventNotifiers* for new values or *Event* occurrences and that generates *Notifications* for them

3.23

NetworkMessage

DataSetMessages and header to facilitate delivery, routing, security and filtering

Note 1 to entry: The *Publisher* hands off the *NetworkMessage* to the *Message Oriented Middleware* (transport layer) to deliver *DataSetMessages* to the *Subscribers*.

Note 2 to entry: The term message is used with various connotations in the messaging world. The *Publisher* might like to think of the message as an immutable payload handed off to the *Message Oriented Middleware* for delivery. The *Subscriber* often thinks of the message as not only that immutable payload from the sender, but also various annotations supplied by the *Message Oriented Middleware* along the way. To avoid confusion the term *DataSetMessage* is used to mean the message as supplied by the *Publisher* for a *DataSet* and the term *NetworkMessage* is used to mean the *DataSetMessage* plus sections for annotation at the head and tail of the *DataSetMessage*.

3.24

Node

fundamental component of an *AddressSpace*

3.25

NodeClass

class of a *Node* in an *AddressSpace*

Note 1 to entry: *NodeClasses* define the metadata for the components of the OPC UA Object Model. They also define constructs, such as *Views*, that are used to organize the *AddressSpace*.

3.26

Notification

generic term for data that announces the detection of an *Event* or of a changed *Attribute* value; *Notifications* are sent in *NotificationMessages*.

3.27

NotificationMessage

Message published from a *Subscription* that contains one or more *Notifications*

3.28

Object

Node that represents a physical or abstract element of a system

Note 1 to entry: *Objects* are modelled using the OPC UA Object Model. Systems, subsystems and devices are examples of *Objects*. An *Object* may be defined as an instance of an *ObjectType*.

3.29

Object Instance

synonym for *Object*

Note 1 to entry: Not all *Objects* are defined by *ObjectTypes*.

3.30

ObjectType

Node that represents the type definition for an *Object*

3.31

OPC UA Application

Client, which calls OPC UA *Services*, or a *Server*, which performs those *Services*, or an OPC UA *Publisher* or an OPC UA *Subscriber*.

3.32

Publisher

entity sending *NetworkMessages* to a *Message Oriented Middleware*

Note 1 to entry: A *Publisher* can be a native OPC UA *Application* or an application that only has knowledge about the *Message Oriented Middleware* and the rules for encoding the *NetworkMessages* and *DataSetMessages*.

3.33

PubSub

OPC UA variant of the publish subscribe messaging pattern

3.34

Profile

specific set of capabilities to which a *Server* may claim conformance.

Note 1 to entry: Each *Server* may claim conformance to more than one *Profile*

Note 2 to entry: The set of capabilities are defined in OPC 10000-7

3.35

Program

executable *Object* that, when invoked, immediately returns a response to indicate that execution has started, and then returns intermediate and final results through *Subscriptions* identified by the *Client* during invocation

3.36

Reference

explicit relationship (a named pointer) from one *Node* to another

Note 1 to entry: The *Node* that contains the *Reference* is the source *Node*, and the referenced *Node* is the target *Node*. All *References* are defined by *ReferenceTypes*.

3.37

ReferenceType

Node that represents the type definition of a *Reference*

Note 1 to entry: The *ReferenceType* specifies the semantics of a *Reference*. The name of a *ReferenceType* identifies how source *Nodes* are related to target *Nodes* and generally reflects an operation between the two, such as "A *Contains* B".

3.38

Server

software application that implements and exposes the *Services* specified in this set of specifications

3.39

Service

Client-callable operation in a *Server*

Note 1 to entry: *Services* are defined in OPC 10000-4. A *Service* is similar to a method call in a programming language or an operation in a Web services WSDL contract.

3.40

Service Set

group of related *Services*

3.41

Session

logical long-running connection between a *Client* and a *Server*.

Note 1 to entry: A *Session* maintains state information between *Service* calls from the *Client* to the *Server*.

3.42

Subscriber

entity receiving *DataSetMessages* from a *Message Oriented Middleware*

Note 1 to entry: A *Subscriber* can be a native OPC UA *Application* or an application that has just knowledge about the *Message Oriented Middleware* and the rules for decoding the *NetworkMessages* and *DataSetMessages*. A *Subscription* in the OPC UA *Client Server* model has a different meaning than the *Subscriber* in the *PubSub* model.

3.43

Subscription

Client-defined endpoint in the *Server*, used to return *Notifications* to the *Client*

Note 1 to entry: "Subscription" is a generic term that describes a set of *Nodes* selected by the *Client* (1) that the *Server* periodically monitors for the existence of some condition, and (2) for which the *Server* sends *Notifications* to the *Client* when the condition is detected.

3.44

Underlying System

Hardware or software platforms that exist as an independent entity. *UA Applications* are dependent on an entity's existence in order to perform UA services. However, the entity is not dependent on *UA Applications*.

Note 1 to entry: Hardware and software platforms include physical hardware, firmware, operating system, networking, non-UA applications, as well as other *UA Applications*. A Distributed Control System, PLC/Device, and UA Server are examples of an *Underlying System*.

3.45

Variable

Node that contains a value

3.46

View

specific subset of the *AddressSpace* that is of interest to the *Client*.

3.47 Abbreviations

| | |
|-------|----------------------------------------------------------------------------------------------------------------------------------|
| A&E | Alarms and Events |
| AMQP | Advanced Message Queuing Protocol |
| API | Application Programming Interface |
| COM | Component Object Model |
| DA | Data Access |
| DCS | Distributed Control System |
| DDS | Data Distribution Service |
| DX | Data Exchange |
| HDA | Historical Data Access |
| HMI | Human-Machine Interface |
| LDAP | Lightweight Directory Access Protocol |
| MES | Manufacturing Execution System |
| MQTT | Message Queue Telemetry Transport |
| OPC | OPC Foundation (a non-profit industry association) formerly an acronym for "OLE for Process Control". Acronym no longer used. |
| PLC | Programmable Logic Controller |
| SCADA | Supervisory Control And Data Acquisition |
| SOAP | Simple Object Access Protocol |
| UA | Unified Architecture |
| UADP | UA Datagram Protocol |
| UDDI | Universal Description, Discovery and Integration |
| UML | Unified Modelling Language |
| WSDL | Web Services Definition Language |
| XML | Extensible Markup Language |
| XMPP | Extensible Messaging and Presence Protocol |

4 Structure of the OPC UA series

4.1 Specification organization

This specification is organized as a multi-part specification, as illustrated in Figure 1.

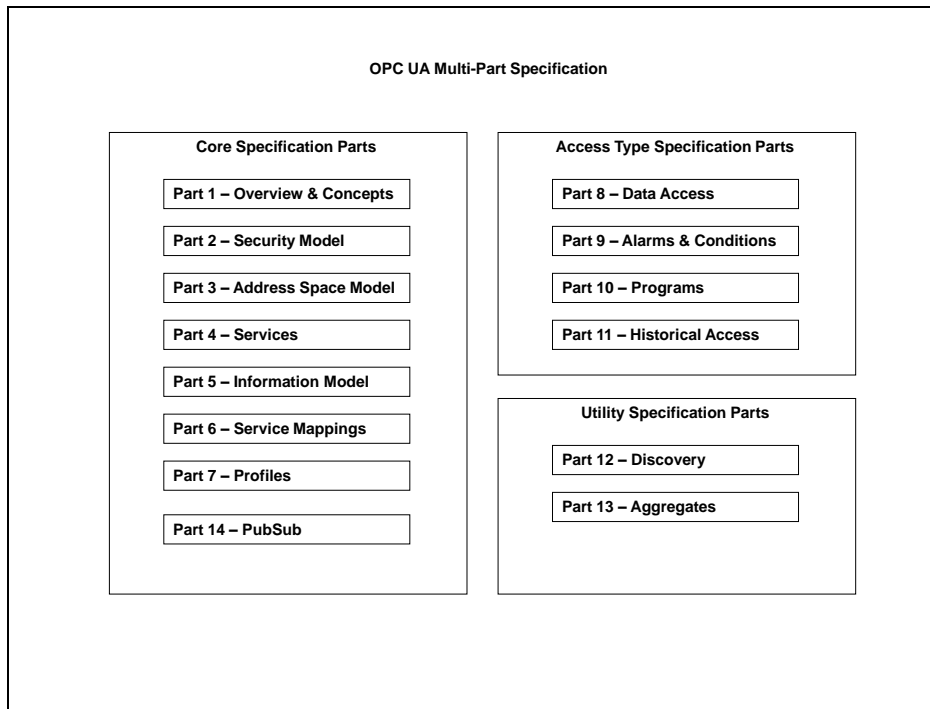

Figure 1 – OPC UA Specification Organization

Parts 1 through 7 and Part 14 specify the core capabilities of OPC UA. These core capabilities define the structure of the OPC *AddressSpace* and the *Services* that operate on it. Part 14 defines an OPC UA publish subscribe pattern in addition to the *Client Server* pattern defined by the *Services* in Part 4. Parts 8 through 11 apply these core capabilities to specific types of access previously addressed by separate OPC COM specifications, such as Data Access (DA), Alarms and Events (A&E) and Historical Data Access (HDA). Part 12 describes *Discovery* mechanisms for OPC UA and Part 13 describes ways of aggregating data.

Readers are encouraged to read Parts 1 through 5 of the core specifications before reading Parts 8 through 14. For example, a reader interested in UA Data Access should read Parts 1 through 5 and 8. References in Part 8 may direct the reader to other parts of this specification.

4.2 Core specification parts

Part 1 (OPC 10000-1) – Overview and Concepts

Part 1 (this part) presents the concepts and overview of OPC UA.

Part 2 (OPC 10000-2) – Security Model

Part 2 describes the model for securing interactions between *OPC UA Applications*.

Part 3 (OPC 10000-3) – Address Space Model

Part 3 describes the contents and structure of the *Server's AddressSpace*.

Part 4 (OPC 10000-4) – Services

Part 4 specifies the *Services* provided by *Servers*.

Part 5 (OPC 10000-5) – Information Model

Part 5 specifies the types and their relationships defined for *Servers*.

Part 6 (OPC 10000-6) – Mappings

Part 6 specifies the mappings to transport protocols and data encodings supported by OPC UA.

Part 7 (OPC 10000-7) – Profiles

Part 7 specifies the *Profiles* that are available for *OPC UA Applications*. These *Profiles* provide groupings of functionality that can be used for conformance level certification. *OPC UA Applications* will be tested against the *Profiles*.

4.3 Access Type specification parts

Part 8 (OPC 10000-8) – Data Access

Part 8 specifies the use of OPC UA for data access.

Part 9 (OPC 10000-9) – Alarms and Conditions

Part 9 specifies use of OPC UA support for access to *Alarms* and *Conditions*. The base system includes support for simple *Events*; this specification extends that support to include support for *Alarms* and *Conditions*.

Part 10 (OPC 10000-10) – Programs

Part 10 specifies OPC UA support for access to *Programs*.

Part 11 (OPC 10000-11) – Historical Access

Part 11 specifies use of OPC UA for historical access. This access includes both historical data and historical *Events*.

4.4 Utility specification parts

Part 12 (OPC 10000-12) – Discovery

Part 12 specifies how *Discovery Servers* operate in different scenarios and describes how *UA Clients* and *Servers* should interact with them. It also defines how *UA* related information should be accessed using common directory service protocols such as LDAP.

Part 13 (OPC 10000-13) – Aggregates

Part 13 specifies how to compute and return aggregates like minimum, maximum, average etc. *Aggregates* can be used with current and historical data.

Part 14 (OPC 10000-14) – PubSub

Part 14 specifies the OPC Unified Architecture (OPC UA) *PubSub* communication model. The *PubSub* communication model defines an OPC UA publish subscribe pattern in addition to the *Client Server* pattern defined by the *Services* in OPC 10000-4.

5 Overview

5.1 UA scope

OPC UA is applicable to components in all industrial domains, such as industrial sensors and actuators, control systems, Manufacturing Execution Systems and Enterprise Resource Planning Systems, including the Industrial Internet of Things (IIoT), Machine To Machine (M2M) as well as Industrie 4.0 and China 2025. These systems are intended to exchange information and to use command and control for industrial processes. OPC UA defines a common infrastructure model to facilitate this information exchange OPC UA specifies the following:

- The information model to represent structure, behaviour and semantics.
- The message model to interact between applications.
- The communication model to transfer the data between end-points.

- The conformance model to guarantee interoperability between systems.

5.2 General

OPC UA is a platform-independent standard through which various kinds of systems and devices can communicate by sending request and response *Messages* between *Clients* and *Servers* or *NetworkMessages* between *Publishers* and *Subscribers* over various types of networks. It supports robust, secure communication that assures the identity of *OPC UA Applications* and resists attacks.

In the *Client Server* model OPC UA defines sets of *Services* that *Servers* may provide, and individual *Servers* specify to *Clients* what *Service* sets they support. Information is conveyed using OPC UA-defined and vendor-defined data types, and *Servers* define object models that *Clients* can dynamically discover. *Servers* can provide access to both current and historical data, as well as *Alarms* and *Events* to notify *Clients* of important changes. OPC UA can be mapped onto a variety of communication protocols and data can be encoded in various ways to trade off portability and efficiency.

In addition to the *Client Server* model, OPC UA defines a mechanism for *Publishers* to transfer the information to *Subscribers* using the *PubSub* model.

5.3 Design goals

OPC UA provides a consistent, integrated *AddressSpace* and service model. This allows a single *Server* to integrate data, *Alarms* and *Events*, and history into its *AddressSpace*, and to provide access to them using an integrated set of *Services*. These *Services* also include an integrated security model.

OPC UA also allows *Servers* to provide *Clients* with type definitions for the *Objects* accessed from the *AddressSpace*. This allows information models to be used to describe the contents of the *AddressSpace*. OPC UA allows data to be exposed in many different formats, including binary structures and XML or JSON documents. The format of the data may be defined by OPC, other standard organizations or vendors. Through the *AddressSpace*, *Clients* can query the *Server* for the metadata that describes the format for the data. In many cases, *Clients* with no pre-programmed knowledge of the data formats will be able to determine the formats at runtime and properly utilize the data.

OPC UA adds support for many relationships between *Nodes* instead of being limited to just a single hierarchy. In this way, a *Server* may present data in a variety of hierarchies tailored to the way a set of *Clients* would typically like to view the data. This flexibility, combined with support for type definitions, makes OPC UA applicable to a wide array of problem domains. As illustrated in Figure 2, OPC UA is not targeted at just the SCADA, PLC and DCS interface, but also as a way to provide greater interoperability between higher level functions.

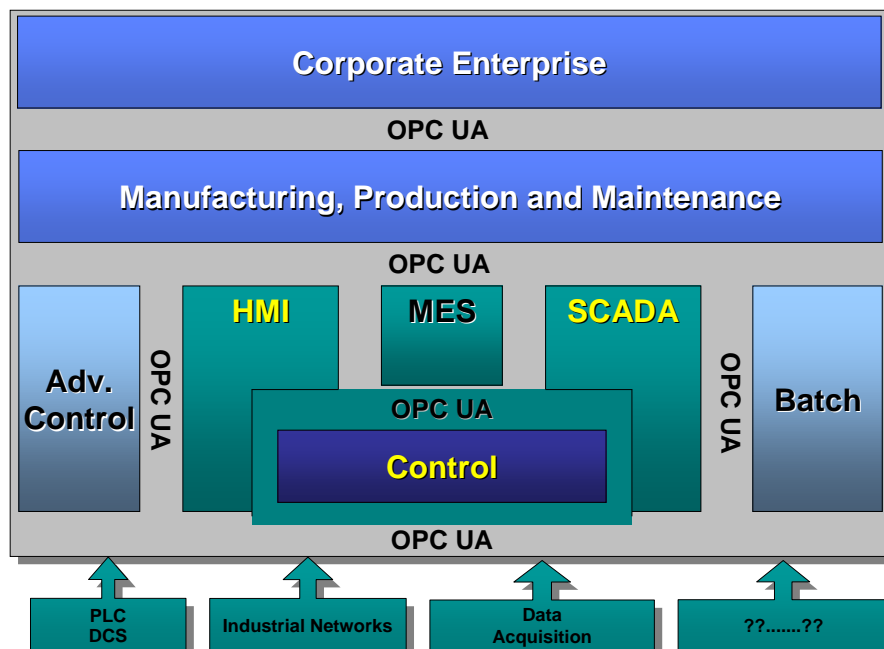

Figure 2 – OPC UA Target applications

OPC UA is designed to provide robustness of published data. A major feature of all OPC servers is the ability to publish data and *Event Notifications*. OPC UA provides mechanisms for *Clients* to quickly detect and recover from communication failures associated with these transfers without having to wait for long timeouts provided by the underlying protocols.

OPC UA is designed to support a wide range of *Servers*, from plant floor PLCs to enterprise *Servers*. These *Servers* are characterized by a broad scope of size, performance, execution platforms and functional capabilities. Therefore, OPC UA defines a comprehensive set of capabilities, and *Servers* may implement a subset of these capabilities. To promote interoperability, OPC UA defines subsets, referred to as *Profiles*, to which *Servers* may claim conformance. *Clients* can then discover the *Profiles* of a *Server*, and tailor their interactions with that *Server* based on the *Profiles*. *Profiles* are defined in OPC 10000-7.

The OPC UA specifications are layered to isolate the core design from the underlying computing technology and network transport. This allows OPC UA to be mapped to future technologies as necessary, without negating the basic design. Mappings and data encodings are described in OPC 10000-6. Three data encodings are defined:

- XML/text
- UA Binary
- JSON

In addition, several protocols are defined:

- OPC UA TCP
- HTTPS
- WebSockets

OPC UA Applications that support multiple transports and encodings will allow the end users to make decisions about trade-offs between performance and compatibility at the time of deployment, rather than having these trade-offs determined by the OPC vendor at the time of product definition.

OPC UA is designed as the migration path for OPC clients and servers that are based on Microsoft COM technology. Care has been taken in the design of OPC UA so that existing data exposed by OPC COM servers (DA, HDA and A&E) can easily be mapped and exposed via OPC UA. Vendors may choose migrating their products natively to OPC UA or use external wrappers to convert from OPC COM to OPC UA and vice-versa. Each of the previous OPC specifications defined its own address space model and its own set of *Services*. OPC UA unifies the previous models into a single integrated address space with a single set of *Services*.

OPC UA *PubSub* opens new application fields for OPC UA. The following are some example uses for *PubSub*:

- Configurable peer to peer communication between controllers and between controllers and HMIs. The peers are not directly connected and do not even need to know about the existence of each other. The data exchange often requires a fixed time-window; it may be point-to-point or a multi-point connection.
- Asynchronous workflows. For example, an order processing application can place an order on a message queue or an enterprise service bus. From there it can be processed by one or more workers.
- Logging to multiple systems. For example, sensors or actuators can write logs to a monitoring system, an HMI, an archive application for later querying, and so on.
- *Servers* representing services or devices can stream data to applications hosted in the cloud. For example, backend servers, big data analytics for system optimization and predictive maintenance.

PubSub is not bound to a particular messaging system. Rather it can be mapped to various different systems as illustrated with two examples:

- *PubSub* with UDP may be well-suited in production environments for frequent transmissions of small amounts of data. It also allows data exchange in one-to-one and one-to-many configurations.
- The use of established messaging protocols (e.g. the ISO/IEC AMQP 1.0 protocol) with JSON data encoding supports the cloud integration path and readily allows handling of the information in modern stream and batch analytics systems.

5.4 Integrated models and services

5.4.1 Security model

5.4.1.1 General

OPC UA security is concerned with the authentication of *Clients* and *Servers*, the authentication of users, the integrity and confidentiality of their communications, and the verifiability of claims of functionality. It does not specify the circumstances under which various security mechanisms are required. That specification is crucial, but it is made by the designers of the system at a given site and may be specified by other standards.

Rather, OPC UA provides a security model, described in OPC 10000-2, in which security measures can be selected and configured to meet the security needs of a given installation. This model includes security mechanisms and parameters. In some cases, the mechanism for exchanging security parameters is defined, but the way that applications use these parameters is not. This framework also defines a minimum set of security *Profiles* that all *OPC UA Applications* support, even though they may not be used in all installations. Security *Profiles* are defined in OPC 10000-7.

5.4.1.2 Discovery and Session establishment

Application level security relies on a secure communication channel that is active for the duration of the application *Session* and ensures the integrity of all *Messages* that are exchanged. This means users need to be authenticated only once, when the application *Session* is established. The mechanisms for discovering *Servers* and establishing secure communication channels and application *Sessions* are described in OPC 10000-4 and OPC 10000-6. Additional information about the *Discovery* process is described in OPC 10000-12.

When a *Session* is established, the *Client* and *Server* applications negotiate a secure communications channel. Digital (X.509) *Certificates* are utilized to identify the *Client* and *Server*. The *Server* further authenticates the user and authorizes subsequent requests to access *Objects* in the *Server*.

5.4.1.3 Auditing

OPC UA includes support for security audit trails with traceability between *Client* and *Server* audit logs. If a security-related problem is detected at the *Server*, the associated *Client* audit log entry can be located and examined. OPC UA also provides the capability for *Servers* to generate *Event Notifications* that report auditable *Events* to *Clients* capable of processing and logging them. OPC UA defines security audit parameters that can be included in audit log entries and in audit *Event Notifications*. OPC 10000-5 defines the data types for these parameters. Not all *Servers* and *Clients* provide all of the auditing features. *Profiles*, found in OPC 10000-7, indicate which features are supported.

5.4.1.4 Transport security

OPC UA security complements the security infrastructure provided by most web service capable platforms.

Transport level security can be used to encrypt and sign *Messages*. Encryption and signatures protect against disclosure of information and protect the integrity of *Messages*. Encryption capabilities are provided by the underlying communications technology used to exchange *Messages* between *OPC UA Applications*. OPC 10000-7 defines the encryption and signature algorithms to be used for a given *Profile*.

5.4.2 Integrated AddressSpace model

The set of *Objects* and related information that the *Server* makes available to *Clients* is referred to as its *AddressSpace*. The OPC UA *AddressSpace* represents its contents as a set of *Nodes* connected by *References*.

Primitive characteristics of *Nodes* are described by OPC-defined *Attributes*. *Attributes* are the only elements of a *Server* that have data values. Data types that define attribute values may be simple or complex.

Nodes in the *AddressSpace* are typed according to their use and their meaning. *NodeClasses* define the metadata for the OPC UA *AddressSpace*. OPC 10000-3 defines the OPC UA *NodeClasses*.

The *Base NodeClass* defines *Attributes* common to all *Nodes*, allowing identification, classification and naming. Each *NodeClass* inherits these *Attributes* and may additionally define its own *Attributes*.

To promote interoperability of *Clients* and *Servers*, the OPC UA *AddressSpace* is structured hierarchically with the top levels the same for all *Servers*. Although *Nodes* in the *AddressSpace* are typically accessible via the hierarchy, they may have *References* to each other, allowing the *AddressSpace* to represent an interrelated network of *Nodes*. The model of the *AddressSpace* is defined in OPC 10000-3.

Servers may subset the *AddressSpace* into *Views* to simplify *Client* access. Subclause 6.3.4.3 describes *AddressSpace Views* in more detail.

5.4.3 Integrated object model

The OPC UA Object Model provides a consistent, integrated set of *NodeClasses* for representing *Objects* in the *AddressSpace*. This model represents *Objects* in terms of their *Variables*, *Events* and *Methods*, and their relationships with other *Objects*. OPC 10000-3 describes this model.

The OPC UA object model allows *Servers* to provide type definitions for *Objects* and their components. Type definitions may be subclassed. They also may be common or they may be system-specific. *ObjectTypes* may be defined by standards organizations, vendors or end-users.

This model allows data, *Alarms* and *Events*, and their history to be integrated into a single *Server*. For example, *Servers* are able to represent a temperature transmitter as an *Object* that is composed of a temperature value, a set of alarm parameters, and a corresponding set of alarm limits.

5.4.4 Integrated services

The interface between *Clients* and *Servers* is defined as a set of *Services*. These *Services* are organized into logical groupings called *Service Sets*. *Service Sets* are discussed in Clause 6.4 and specified in OPC 10000-4.

OPC UA *Services* provide two capabilities to *Clients*. They allow *Clients* to issue requests to *Servers* and receive responses from them. They also allow *Clients* to subscribe to *Servers* for *Notifications*. *Notifications* are used by the *Server* to report occurrences such as *Alarms*, data value changes, *Events*, and *Program* execution results.

OPC UA *Messages* may be encoded as XML text or in binary format for efficiency purposes. They may be transferred using multiple underlying transports, for example TCP or web services over HTTP. *Servers* may provide different encodings and transports as defined by OPC 10000-6.

5.5 Sessions

OPC UA *Client Server* interaction requires a stateful model. The state information is maintained inside an application *Session*. Examples of state-information are *Subscriptions*, user credentials and continuation points for operations that span multiple requests.

Sessions are defined as logical connections between *Clients* and *Servers*. *Servers* may limit the number of concurrent *Sessions* based on resource availability, licensing restrictions, or other constraints. Each *Session* is independent of the underlying communications protocols. Failures of these protocols do not automatically cause the *Session* to terminate. *Sessions* terminate based on *Client* or *Server* request, or based on inactivity of the *Client*. The inactivity time interval is negotiated during *Session* establishment.

6 Systems concepts

6.1 Client Server Overview

The OPC UA systems architecture models *Clients* and *Servers* as interacting partners. Each system may contain multiple *Clients* and *Servers*. Each *Client* may interact concurrently with one or more *Servers*, and each *Server* may interact concurrently with one or more *Clients*. An application may combine *Server* and *Client* components to allow interaction with other *Servers* and *Clients* as described in 6.3.7.

Clients and *Servers* are described in the sub-clauses 6.2 and 6.3. Figure 3 illustrates the architecture that includes a combined *Server* and *Client*.

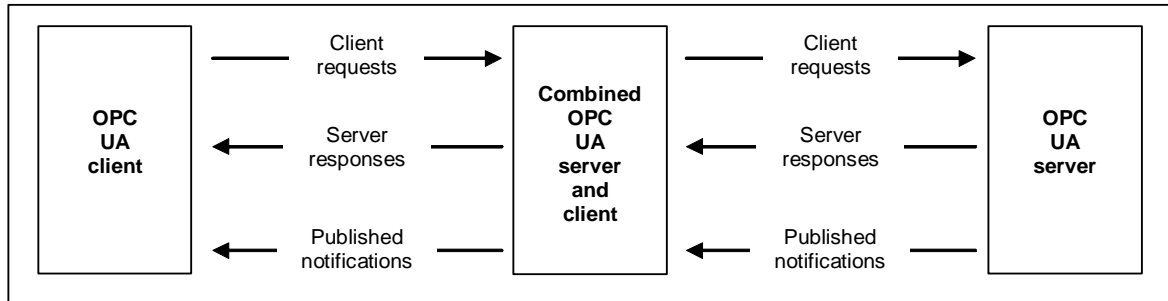

Figure 3 – OPC UA System architecture

6.2 OPC UA Clients

The OPC UA *Client* architecture models the *Client* endpoint of client/server interactions. Figure 4 illustrates the major elements of a typical *Client* and how they relate to each other.

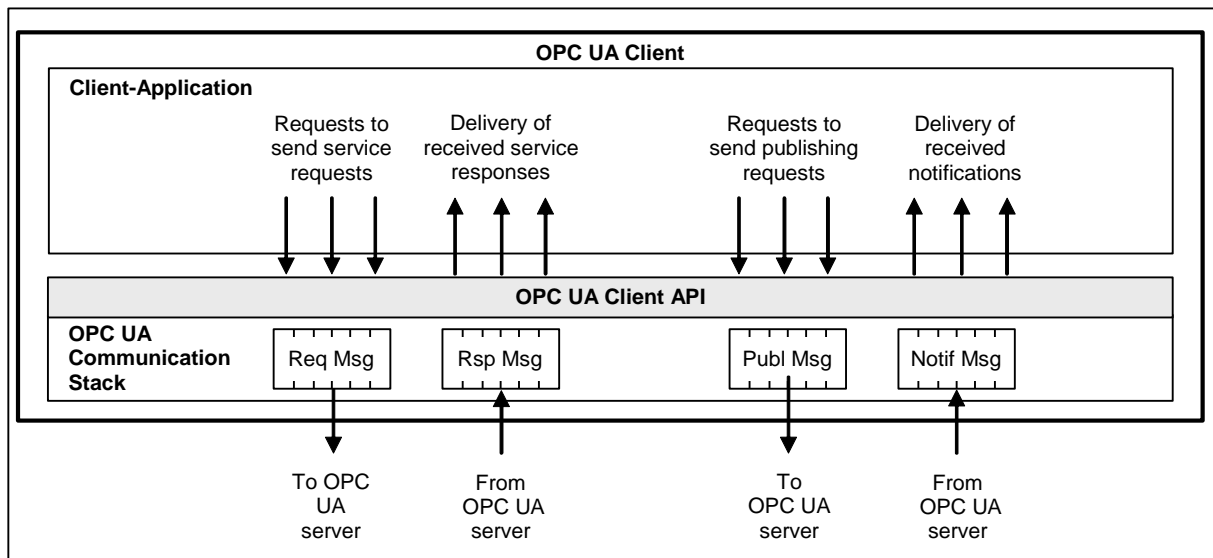

Figure 4 – OPC UA Client architecture

The *Client* Application is the code that implements the function of the *Client*. It uses the *Client* API to send and receive OPC UA *Service* requests and responses to the *Server*. The *Services* defined for OPC UA are described in Clause 6.4, and specified in OPC 10000-4.

Note that the “*Client* API” is an internal interface that isolates the *Client* application code from an OPC UA Communication Stack. The OPC UA Communication Stack converts *Client* API calls into *Messages* and sends them through the underlying communications entity to the *Server* at the request of the *Client* application. The OPC UA Communication Stack also receives response and *NotificationMessages* from the underlying communications entity and delivers them to the *Client* application through the *Client* API.

6.3 OPC UA Servers

6.3.1 General

The OPC UA *Server* architecture models the *Server* endpoint of client/server interactions. Figure 5 illustrates the major elements of the *Server* and how they relate to each other.

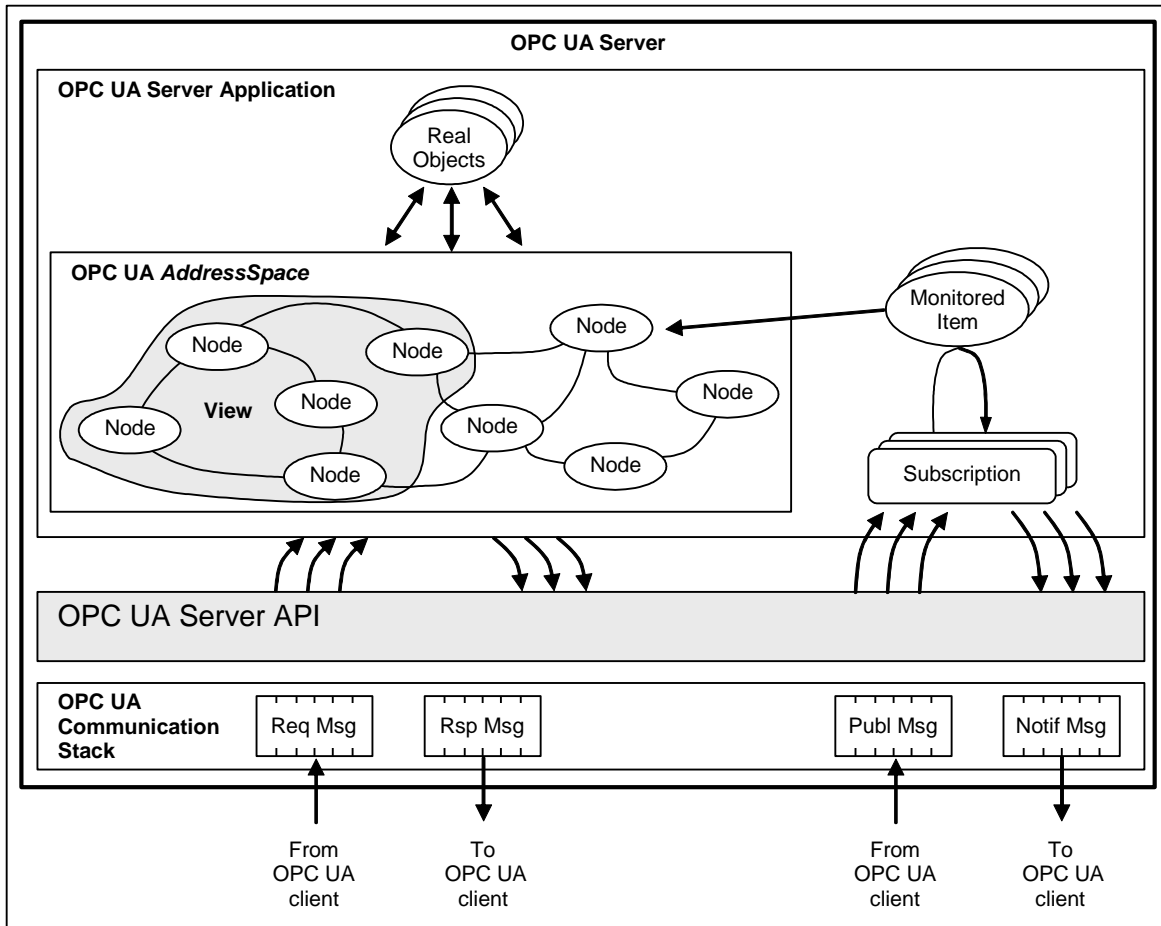

Figure 5 – OPC UA Server architecture

6.3.2 Real objects

Real objects are physical or software objects that are accessible by the *Server* application or that it maintains internally. Examples include physical devices and diagnostics counters.

6.3.3 Server application

The *Server* application is the code that implements the function of the *Server*. It uses the *Server* API to send and receive OPC UA *Messages* from *Clients*. Note that the “*Server* API” is an internal interface that isolates the *Server* application code from an OPC UA Communication Stack.

6.3.4 OPC UA AddressSpace

6.3.4.1 AddressSpace Nodes

The *AddressSpace* is modelled as a set of *Nodes* accessible by *Clients* using OPC UA *Services* (interfaces and methods). *Nodes* in the *AddressSpace* are used to represent real objects, their definitions and their *References* to each other.

6.3.4.2 AddressSpace organization

OPC 10000-3 contains the details of the meta model “building blocks” used to create an *AddressSpace* out of interconnected *Nodes* in a consistent manner. *Servers* are free to organize their *Nodes* within the *AddressSpace* as they choose. The use of *References* between *Nodes* permits *Servers* to organize the *AddressSpace* into hierarchies, a full mesh network of *Nodes*, or any possible mix.

OPC 10000-5 defines OPC UA *Nodes* and *References* and their expected organization in the *AddressSpace*. Some *Profiles* will not require that all of the UA *Nodes* be implemented.

6.3.4.3 AddressSpace Views

A *View* is a subset of the *AddressSpace*. *Views* are used to restrict the *Nodes* that the *Server* makes visible to the *Client*, thus restricting the size of the *AddressSpace* for the *Service* requests submitted by the *Client*. The default *View* is the entire *AddressSpace*. *Servers* may optionally define other *Views*. *Views* hide some of the *Nodes* or *References* in the *AddressSpace*. *Views* are visible via the *AddressSpace* and *Clients* are able to browse *Views* to determine their structure. *Views* are often hierarchies, which are easier for *Clients* to navigate and represent in a tree.

6.3.4.4 Support for information models

The OPC UA *AddressSpace* supports information models. This support is provided through:

- a) *Node References* that allow *Objects* in the *AddressSpace* to be related to each other.
- b) *ObjectType Nodes* that provide semantic information for real *Objects* (type definitions).
- c) *ObjectType Nodes* to support subclassing of type definitions.
- d) Data type definitions exposed in the *AddressSpace* that allow industry specific data types to be used.
- e) OPC UA companion standards that permit industry groups to define how their specific information models are to be represented in *Server AddressSpace*.

6.3.5 Subscription entities

6.3.5.1 MonitoredItems

MonitoredItems are entities in the *Server* created by the *Client* that monitor *AddressSpace Nodes* and their real-world counterparts. When they detect a data change or an event/alarm occurrence, they generate a *Notification* that is transferred to the *Client* by a *Subscription*.

6.3.5.2 Subscriptions

A *Subscription* is an endpoint in the *Server* that publishes *Notifications* to *Clients*. *Clients* control the rate at which publishing occurs by sending *Publish Messages*.

6.3.6 OPC UA Service Interface

6.3.6.1 General

The *Services* defined for OPC UA are described in Clause 6.4, and specified in OPC 10000-4.

6.3.6.2 Request/response Services

Request/response *Services* are *Services* invoked by the *Client* through the OPC UA *Service Interface* to perform a specific task on one or more *Nodes* in the *AddressSpace* and to return a response.

6.3.6.3 Subscription Services

The *Publish Service* is invoked through the OPC UA *Service Interface* for the purpose of periodically sending *Notifications* to *Clients*. *Notifications* include *Events*, *Alarms*, data changes and *Program* outputs.

6.3.7 Server to Server interactions

Server to Server interactions in the *Client Server* model are interactions in which one *Server* acts as a *Client* of another *Server*. *Server to Server* interactions allow for the development of servers that:

- a) exchange information with each other on a peer-to-peer basis, this could include redundancy or remote *Servers* that are used for maintaining system wide type definitions (see Figure 6),
- b) are chained in a layered architecture of *Servers* to provide:
 - 1) aggregation of data from lower-layer *Servers*,
 - 2) higher-layer data constructs to *Clients*, and
 - 3) concentrator interfaces to *Clients* for single points of access to multiple underlying *Servers*.

Figure 6 illustrates interactions between Servers.

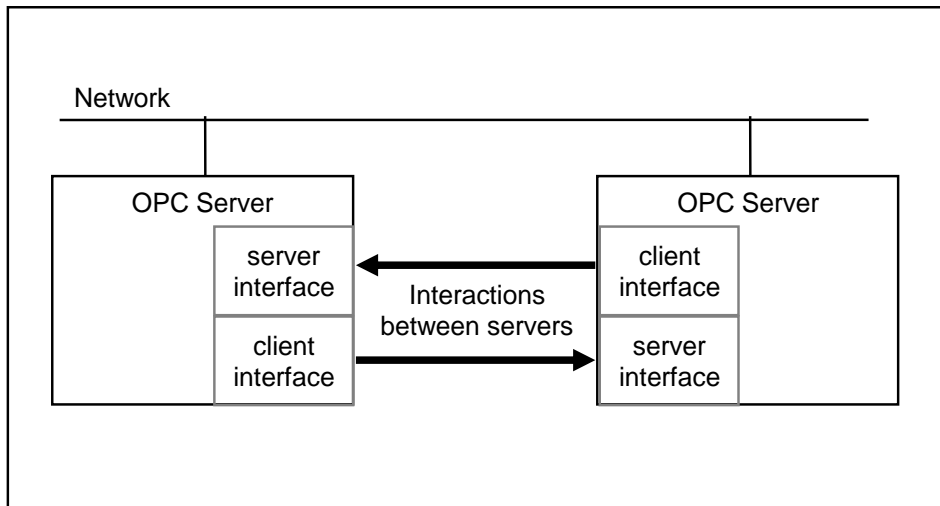

Figure 6 – Peer-to-peer interactions between Servers

Similar peer-to-peer interactions can also be accomplished using the OPC UA *PubSub* model where each peer *Application* is both a *Publisher* and a *Subscriber*.

Figure 7 extends the previous example and illustrates the chaining of Servers together for vertical access to data in an enterprise.

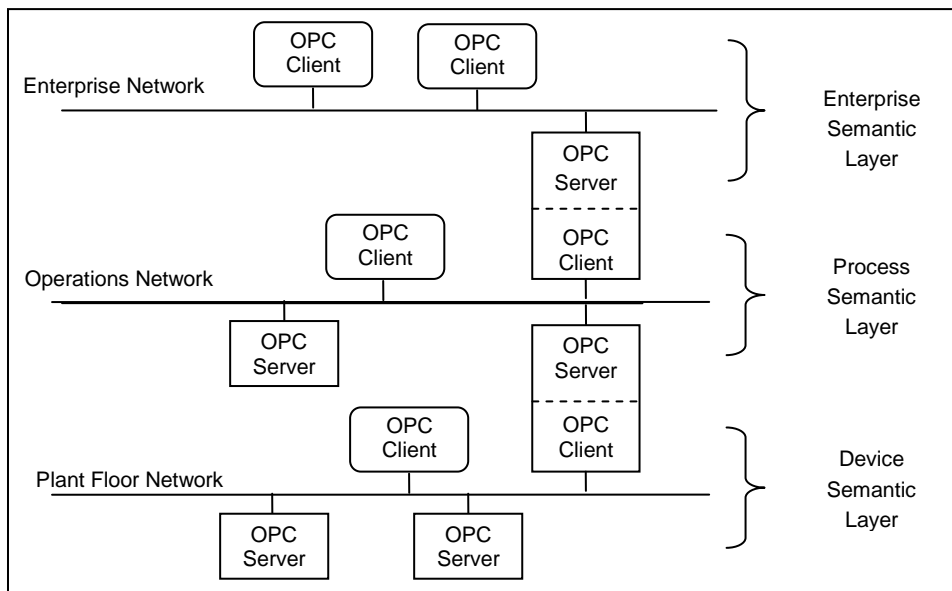

Figure 7 – Chained Server example

6.4 Redundancy

OPC UA provides the data structures and services by which *Redundancy* may be achieved in a standardized manner. Redundancy may be used for high availability, fault tolerance and load balancing. OPC 10000-4 formally defines *Client*, *Server* and *Network Redundancy*. Only some *Profiles* OPC 10000-7 will require redundancy support, but not the base *Profile*.

Required client and server behaviours are associated with two distinct modes of *Server Redundancy*, transparent and non-transparent. The *Client* and *Server* responsibilities when using either transparent or non-transparent redundancy are defined in OPC 10000-4.

Servers that support non-transparent redundancy can also support client controlled load balancing. The health of a *Server* including its ability to *Service* requests is collectively defined as *ServiceLevel*. See OPC 10000-5 for a formal definition of *ServiceLevel*. OPC 10000-4 defines four distinct *ServiceLevel* sub-ranges and example usage.

6.5 Publish-Subscribe

With *PubSub*, *OPC UA Applications* do not directly exchange requests and responses. Instead, *Publishers* send messages to a *Message Oriented Middleware*, without knowledge of what, if any, *Subscribers* there may be. Similarly, *Subscribers* express interest in specific types of data, and process messages that contain this data, without knowledge of what *Publishers* there are.

Message Oriented Middleware is software or hardware infrastructure supporting sending and receiving messages between distributed systems. It depends on the *Message Oriented Middleware* how this distribution is implemented.

To cover a large number of use cases, *OPC UA PubSub* supports two largely different *Message Oriented Middleware* variants. These are:

- A broker-less form, where the *Message Oriented Middleware* is the network infrastructure that is able to route datagram-based messages. *Subscribers* and *Publishers* use datagram protocols like UDP multicast.
- A broker-based form, where the *Message Oriented Middleware* is a *Broker*. *Subscribers* and *Publishers* use standard messaging protocols like AMQP or MQTT to communicate with the *Broker*. All messages are published to specific queues (e.g. topics, nodes) that the *Broker* exposes and *Subscribers* can listen to these queues. The *Broker* may translate messages from the formal messaging protocol of the *Publisher* to the formal messaging protocol of the *Subscriber*.

PubSub is used to communicate messages between different system components without these components having to know each other's identity.

A *Publisher* is pre-configured with what data to send. There is no connection establishment between *Publisher* and *Subscriber*.

The knowledge about who *Subscribers* are and the forwarding of published data to the *Subscribers* is off-loaded to the *Message Oriented Middleware*. The *Publisher* does not know or even care if there is one or many *Subscribers*. Effort and resource requirements for the *Publisher* are predictable and do not depend on the number of *Subscribers*.

OPC 10000-14 describes the details of the *OPC UA PubSub* model.

6.6 Synergy of models

PubSub and *Client Server* are both based on the *OPC UA Information Model*. *PubSub* therefore can easily be integrated into *Servers* and *Clients*. Quite typically, a *Publisher* will be an *Server* (the owner of information) and a *Subscriber* is often a *Client*. Above all, the *PubSub Information Model* for configuration promotes the configuration of *Publishers* and *Subscribers* using the *OPC UA Client Server* model. Figure 8 depicts a single *OPC UA Application* that acts as both a *Server* and a *Publisher*.

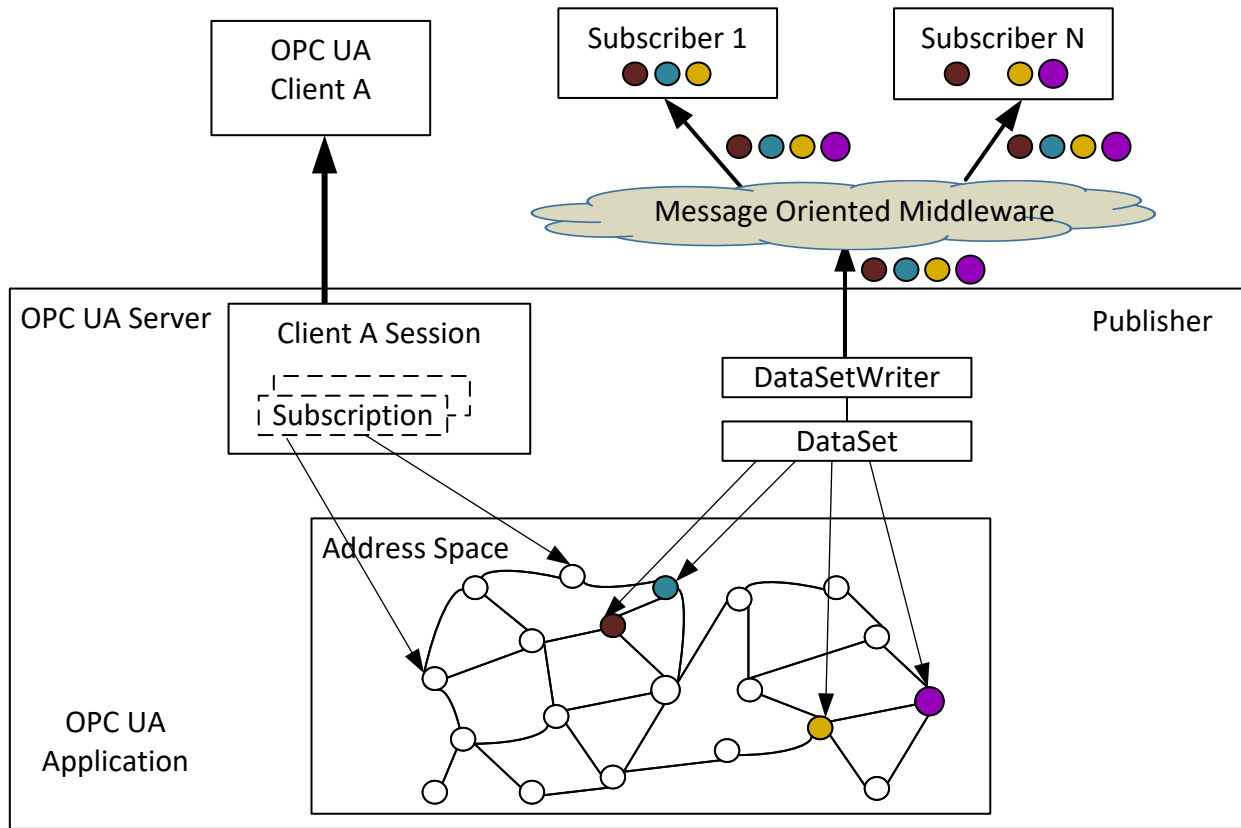

Figure 8 – Integrated Client Server and PubSub models

Nevertheless, the *PubSub* communication does not require such a role dependency. I.e., *Clients* can be *Publishers* and *Servers* can be *Subscribers*. In fact, there is no necessity for *Publishers* or *Subscribers* to be either a *Server* or a *Client* to participate in *PubSub* communications.

7 Service Sets

7.1 General

OPC UA *Services* are divided into *Service Sets*, each defining a logical grouping of *Services* used to access a particular aspect of the *Server*. The *Service Sets* are described below. The *Service Sets* and their *Services* are specified in OPC 10000-4. Whether or not a *Server* supports a *Service Set*, or a specific *Service* within a *Service Set*, is defined by its *Profile*. *Profiles* are described in OPC 10000-7.

7.2 Discovery Service Set

This *Service Set* defines *Services* used to discover *Servers* that are available in a system. It also provides a manner in which clients can read the security configuration required for connection to the *Server*. The *Discovery Services* are implemented by individual *Servers* and by dedicated *Discovery Servers*. Well known dedicated *Discovery Servers* provide a way for clients to discover all registered *Servers*. OPC 10000-12 describes how to use the *Discovery Services* with dedicated *Discovery Servers*.

7.3 SecureChannel Service Set

This *Service Set* defines *Services* used to open a communication channel that ensures the confidentiality and integrity of all *Messages* exchanged with the *Server*. The base concepts for UA security are defined in OPC 10000-2.

The *SecureChannel Services* are unlike other *Services* because they are typically not implemented by the *OPC UA Application* directly. Instead, they are provided by the communication stack that the *OPC UA Application* is built on. *OPC UA Applications* simply need to verify that a *SecureChannel* is active whenever it receives a *Message*. OPC 10000-6 describes how the *SecureChannel Services* are implemented with different types of communication stacks.

A *SecureChannel* is a long-running logical connection between a single *Client* and a single *Server*. This channel maintains a set of keys that are known only to the *Client* and *Server* and that are used to authenticate and encrypt *Messages* sent across the network. The *SecureChannel Services* allow the *Client* and *Server* to securely negotiate the keys to use.

The exact algorithms used to authenticate and encrypt *Messages* are described in the security policies for a *Server*. These policies are exposed via the *Discovery Service Set*. A *Client* selects the appropriate endpoint that supports the desired security policy by the *Server* when it creates a *SecureChannel*.

When a *Client* and *Server* are communicating via a *SecureChannel* they verify that all incoming *Messages* have been signed and/or encrypted according to the security policy. A UA application is expected to ignore any *Message* that does not conform to the security policy for the channel.

A *SecureChannel* is separate from the *UA Application Session*; however, a single *UA Application Session* may only be accessed via a single *SecureChannel*. This implies that the *UA application* is able to determine what *SecureChannel* is associated with each *Message*. A communication stack that provides a *SecureChannel* mechanism but that does not allow the application to know what *SecureChannel* was used for a given *Message* cannot be used to implement the *SecureChannel Service Set*.

The relationship between the *UA Application Session* and the *SecureChannel* is illustrated in Figure 9. The UA applications use the communication stack to exchange *Messages*. First, the *SecureChannel Services* are used to establish a *SecureChannel* between the two communication stacks, allowing them to exchange *Messages* in a secure way. Second, the UA applications use the *Session Service Set* to establish a *UA application Session*.

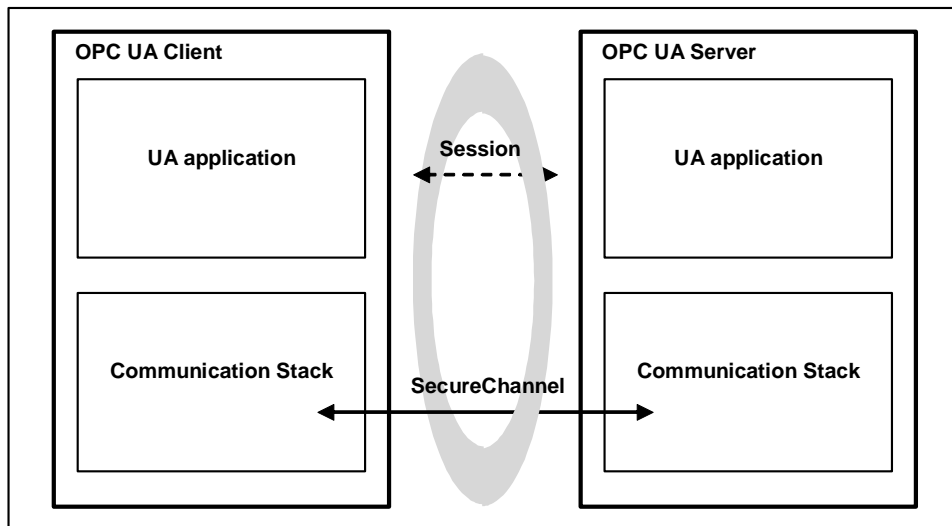

Figure 9 – SecureChannel and Session Services

7.4 Session Service Set

This *Service Set* defines *Services* used to establish an application-layer connection in the context of a *Session* on behalf of a specific user.

7.5 NodeManagement Service Set

The NodeManagement Service Set allows Clients to add, modify, and delete Nodes in the AddressSpace. These Services provide an interface for the configuration of Servers.

7.6 View Service Set

Views are publicly defined, *Server-created* subsets of the *AddressSpace*. The entire *AddressSpace* is the default *View*, and therefore, the *View Services* are capable of operating on the entire *AddressSpace*. Future versions of this specification may also define *Services* to create *Client* defined *Views*.

The *View Service Set* allows *Clients* to discover *Nodes* in a *View* by browsing. Browsing allows *Clients* to navigate up and down the hierarchy, or to follow *References* between *Nodes* contained in the *View*. In this manner, browsing also allows *Clients* to discover the structure of the *View*.

7.7 Query Service Set

The Query Service Set allows users to access the address space without browsing and without knowledge of the logical schema used for internal storage of the data.

Querying allows *Clients* to select a subset of the *Nodes* in a *View* based on some *Client*-provided filter criteria. The *Nodes* selected from the *View* by the query statement are called a result set.

Servers may find it difficult to process queries that require access to runtime data, such as device data, that involves resource intensive operations or significant delays. In these cases, the *Server* may find it necessary to reject the query.

7.8 Attribute Service Set

The *Attribute Service Set* is used to read and write *Attribute* values. *Attributes* are primitive characteristics of *Nodes* that are defined by OPC UA. They may not be defined by *Clients* or *Servers*. *Attributes* are the only elements in the *AddressSpace* permitted to have data values. A special *Attribute*, the *Value Attribute* is used to define the value of *Variables*.

7.9 Method Service Set

Methods represent the function calls of *Objects*. They are defined in OPC 10000-3. *Methods* are invoked and return after completion, whether successful or unsuccessful. Execution times for *Methods* may vary, depending on the function they are performing.

The *Method Service Set* defines the means to invoke *Methods*. A *Method* is always a component of an *Object*. Discovery is provided through the browse and query *Services*. *Clients* discover the *Methods* supported by a *Server* by browsing for the owning *Objects* that identify their supported *Methods*.

Because *Methods* may control some aspect of plant operations, method invocation may depend on environmental or other conditions. This may be especially true when attempting to re-invoke a *Method* immediately after it has completed execution. Conditions that are required to invoke the *Method* may not yet have returned to the state that permits the *Method* to start again. In addition, some *Methods* may be capable of supporting concurrent invocations, while others may have a single invocation executing at a given time.

7.10 MonitoredItem Service Set

The *MonitoredItem Service Set* is used by the *Client* to create and maintain *MonitoredItems*. *MonitoredItems* monitor *Variables*, *Attributes* and *EventNotifiers*. They generate *Notifications* when they detect certain conditions. They monitor *Variables* for a change in value or status; *Attributes* for a change in value; and *EventNotifiers* for newly generated *Alarm* and *Event* reports.

Each *MonitoredItem* identifies the item to monitor and the *Subscription* to use to periodically publish *Notifications* to the *Client* (see 7.11). Each *MonitoredItem* also specifies the rate at which the item is to be monitored (sampled) and, for *Variables* and *EventNotifiers*, the filter criteria used to determine when a *Notification* is to be generated. Filter criteria for *Attributes* are specified by their *Attribute* definitions in OPC 10000-4.

The sample rate defined for a *MonitoredItem* may be faster than the publishing rate of the *Subscription*. For this reason, the *MonitoredItem* may be configured to either queue all *Notifications* or to queue only the latest *Notification* for transfer by the *Subscription*. In this latter case, the queue size is one.

MonitoredItem Services also define a monitoring mode. The monitoring mode is configured to disable sampling and reporting, to enable sampling only, or to enable both sampling and reporting. When sampling is enabled, the *Server* samples the item. In addition, each sample is evaluated to determine if a *Notification* should be generated. If so, the *Notification* is queued. If reporting is enabled, the queue is made available to the *Subscription* for transfer.

Finally, *MonitoredItems* can be configured to trigger the reporting of other *MonitoredItems*. In this case, the monitoring mode of the items to report is typically set to sampling only, and when the triggering

item generates a *Notification*, any queued *Notifications* of the items to report are made available to the *Subscription* for transfer.

7.11 Subscription Service Set

The *Subscription Service Set* is used by the *Client* to create and maintain *Subscriptions*. *Subscriptions* are entities that periodically publish *NotificationMessages* for the *MonitoredItem* assigned to them (see 7.9). The *NotificationMessage* contains a common header followed by a series of *Notifications*. The format of *Notifications* is specific to the type of item being monitored (i.e. *Variables*, *Attributes*, and *EventNotifiers*).

Once created, the existence of a *Subscription* is independent of the *Client's Session* with the *Server*. This allows one *Client* to create a *Subscription*, and a second, possibly a redundant *Client*, to receive *NotificationMessages* from it.

To protect against non-use by *Clients*, *Subscriptions* have a configured lifetime that *Clients* periodically renew. If any *Client* fails to renew the lifetime, the lifetime expires and the *Subscription* is closed by the *Server*. When a *Subscription* is closed, all *MonitoredItems* assigned to the *Subscription* are deleted.

Subscriptions include features that support detection and recovery of lost *Messages*. Each *NotificationMessage* contains a sequence number that allows *Clients* to detect missed *Messages*. When there are no *Notifications* to send within the keep-alive time interval, the *Server* sends a keep-alive *Message* that contains the sequence number of the next *NotificationMessage* sent. If a *Client* fails to receive a *Message* after the keep-alive interval has expired, or if it determines that it has missed a *Message*, it can request the *Server* to resend one or more *Messages*.
